

THIS DRAWING IS UNPUBLISHED. RELEASED FOR PUBLICATION, 19 .
 © COPYRIGHT 19 BY AMP INCORPORATED. ALL RIGHTS RESERVED.

LOC	DIST	REVISIONS			
P	LTR	DESCRIPTION	DATE	DWN	APVD
AF	50	K	REV PER OG3A-0679-03	27OCT03	JR DD

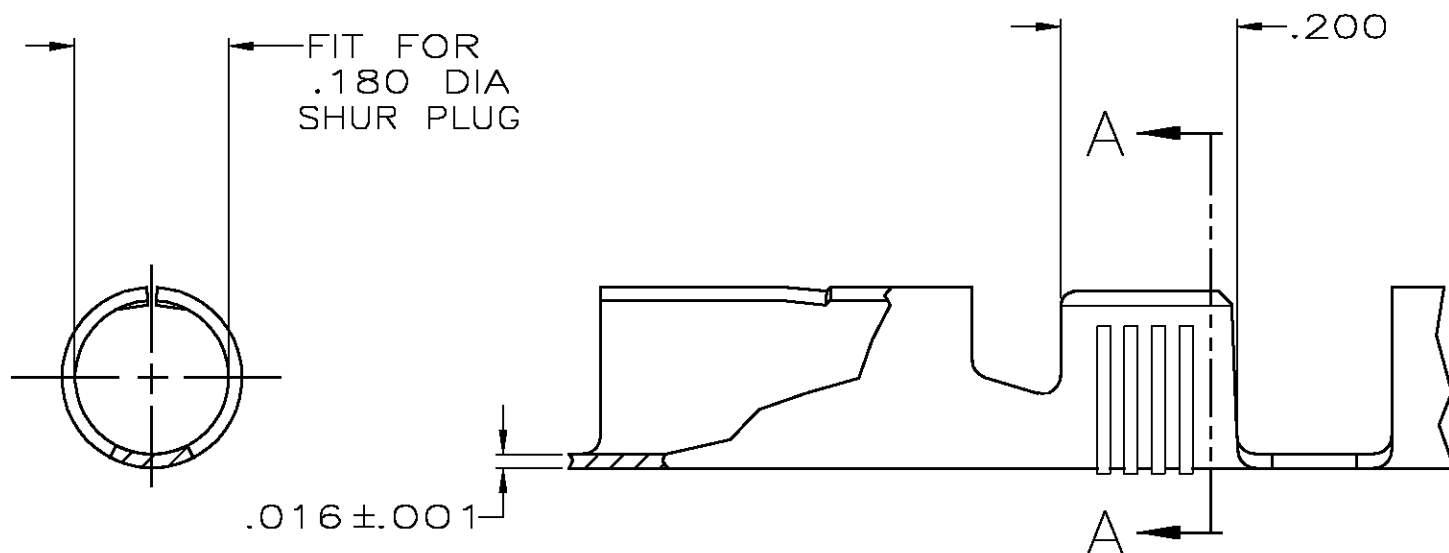

- 1 CONTINUOUS STRIP ON REELS.
- △2 .000080 MIN TIN PLATE.
- △3 .000080 MIN TIN PLATE OVER .000050 MIN NICKEL UNDERPLATE.
- △4 .000150 MIN NICKEL PLATE
- △5 PRELIMINARY — NOT FOR PRODUCTION

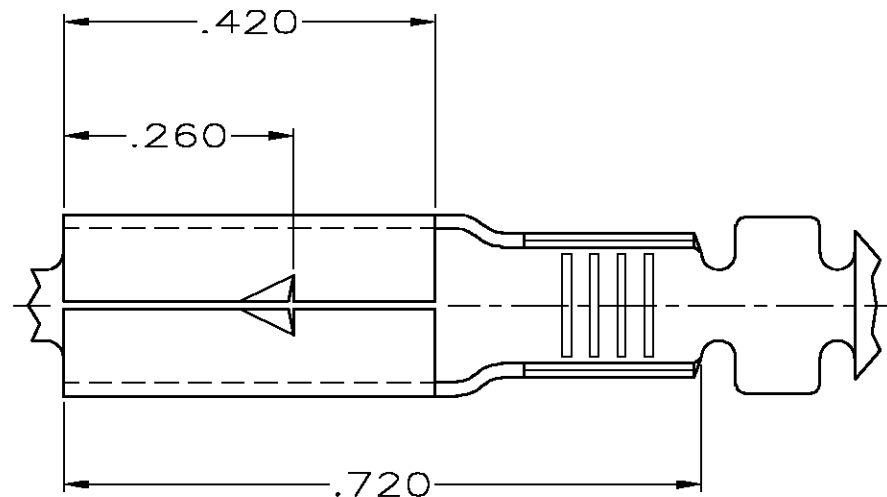
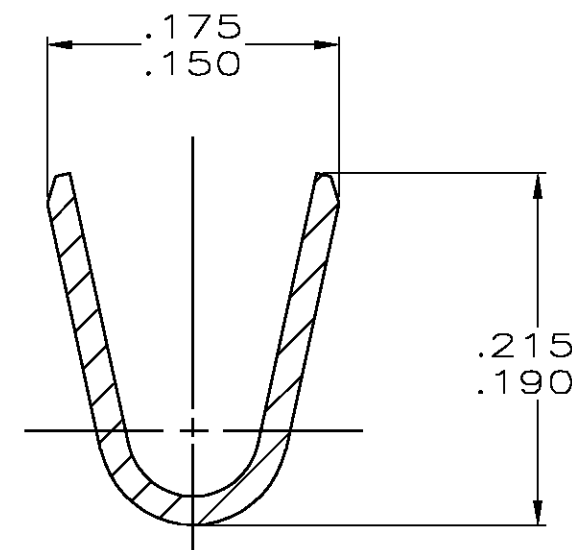

△4	14-10 AWG	△5	42868-4
△3	14-10 AWG		42868-3
△2	14-10 AWG		42868-2
-	14-10 AWG		42868-1
FINISH		WIRE RANGE	
		PART NUMBER	

DIMENSIONS: INCHES		TOLERANCES UNLESS OTHERWISE SPECIFIED:	
	0 PLC	±-	
	1 PLC	±-	
	2 PLC	±-	
	3 PLC	±.010	
	4 PLC	±-	
	ANGLES	±-	
MATERIAL: 4M BRASS		FINISH: SEE TABLE	

DWN: MICHAEL S. FEHER 12JUL2001	AMP Incorporated Harrisburg, PA 17105-3608		
CHK: DONALD DECKER 12JUL2001	NAME: RECEPTACLE, SHUR PLUG, .180 DIA		
APVD: DONALD DECKER 12JUL2001	SIZE: A3	CAGE CODE: 00779	DRAWING NO: 42868
PRODUCT SPEC: -	RESTRICTED TO: -		SCALE: 5:1
APPLICATION SPEC: 114-2017	SHEET: 1 OF 1		REV: K
WEIGHT: -	CUSTOMER DRAWING		